

# **2009 UMP Modified Rules**

## **TO ALL COMPETITORS/PARTICIPANTS**

- ❖ Under the guideline of the 2009 DIRTcar UMP Modified rules any and/or rules and as stated in the 2009 DIRTcar Rule Book, all DIRTcar rules applies to all divisions, except in instances where any local track rules, pertaining to any item are listed in the local track rules, whether that is in the technical components and/or the racing procedures and/or overall rules that are administered by the local track officials and management. In those instances and where applicable, the local track rules shall prevail.
- ❖ The 2009 DIRTcar UMP Modified Rules have been established to include the rules in several different regions of North America, refer to the rules that are in effect in your region.
- ❖ The following are the 2009 UMP Modified rules. All amendments supersede any previous rules regarding any technical article and/or aspect.
- ❖ Under the guideline of the 2009 UMP Modified rules any and/or rules and as stated in the 2009 DIRTcar Rule Book, all DIRTcar rules apply to all sanctioned divisions.
- ❖ The specifications published shall be considered a section of the “*Official Rules and Specifications*” for all events, series and sanctions by World Racing Group. All sections should be considered when determining specifications and governance.

### **15.0 UMP Modifieds**

ANY CAR, TEAM AND/OR DRIVER THAT DOES NOT MEET THESE SPECIFICATIONS AND/OR EQUIPMENT REQUIREMENTS WILL BE SUBJECT TO PENALTIES AS DETERMINED BY THE DIRTcar and/or World Racing Group OFFICIALS

#### **15.1 – Engine**

- A.) Any American made engine will be permitted as long as the rear of the engine bell housing flange is mounted at least 72”-inches forward from the center of the rear axle. The engine offset must remain within two (2”) inches of the center line from the cross member. The minimum engine height when measured from the ground to the center of the crankshaft is 11” inches.
- B.) All engines used in competition must be able to be used in a conventional passenger car without alteration. Alteration of motor mounts will not be permitted. Alteration of the castings and/or fittings will not be permitted. Any machine work on the outside of the engine or machine work on the front or rear of the crankshaft will not be permitted.
- C.) Aluminum blocks will not be permitted.
- D.) Magnetos will not be permitted.
- E.) Wet sump oiling systems must be operative and will go with a claim by DIRTcar officials. Overall dry sump systems will not be permitted.
- F.) Alteration to the cooling system will be permitted. If alterations to the cooling system are made the stock-appearing hood line must be maintained.
- G.) The battery must be securely mounted and shielded. The battery must not be mounted inside the driver’s cockpit.
- H.) The exhaust system(s) must be mounted with the exhaust directed away from the vehicle and/or away from the ground (preferably horizontal and outside the body of the car). A maximum of 1/2” inch clearance surrounding the header pipe when directed through the firewall on the driver’s side. Local track rules will prevail when decibel and/or muffler rules.
- I.) One two or four barrel carburetor is required.

- J.) The engine must be a normally aspirated configuration.
- K.) Fuel injection systems or electric fuel pumps will not be permitted.
- L.) There may be specific engine rules issued for each region of North America that deviate from the standard UMP Modified Engine rules included herein.

#### **15.1.1 Engine Claims**

A.) Any qualified UMP Modified competitor has the right to claim any engine at any time during an UMP Modified event. To begin the claim a \$550.00 fee, plus the agreement to an engine exchange in addition to \$50.00 for the tow truck operator. All claims do not include: flywheel, clutch, pressure plate, bell housing, headers, carburetor, starter, fan & pulleys, motor mount, sending units and switches for oil pressure and water temperature, carburetor adaptor, clutch ball, clutch arm, throw out bearings, dip stick, water pump, distributor, plug wires or fuel pump.

B.) Any competitor who processes a claim must have taken the checkered flag in the feature race and have finished the feature race on the 'lead lap'. The claim must be presented in cash or certified check to promoter or designated DIRTcar official within five (5) minutes after the completion of the feature race. The driver must have the claim payment and his/her DIRTcar current/valid membership and claim card available. A third party cannot provide these items to the claiming driver. (Yearly membership runs from January 1 through December 31.) All claims, positive or negative, must be reported immediately to DIRTcar headquarters by the event promoter and/or chief steward of the event. Drivers will only have the ability to make two (2) claims in any UMP Modified season. A driver can claim another driver's engine only once during the year. Only the engine of the event winner can be claimed. In case of multiple claims on the same engine, the engine will go to a qualified driver who finished the furthest back in the field on the lead lap. Drivers may not claim an engine if he/she has spun out and caused a caution period. If a claim is refused, the claim is not held against the claiming driver. The claim rule is intended to maintain cost effectiveness and a level playing field in the UMP Modified division.

C.) Any driver making a claim must drive his/her car immediately after the finish of the feature, under its own power, directly to the claiming area. Only drivers and officials will be permitted in the claim area. The claim area must be designated by the promoter to all drivers at the driver's meeting prior to the feature event. The feature winner must go to the claim area immediately following the finish of the feature event. If no driver comes immediately to the claiming area, the winner may proceed as directed.

D.) The claimed engine must be completely removed within one (1) hour from the time the claim is made.

E.) The first sell/no sell or trade of the engine by the driver being claimed is considered binding.

F.) Only a qualified driver may claim an engine and only the winning driver may agree to sell.

G.) Any refusal to sell forfeits all cash, trophies and contingency winnings for the feature as well as all DIRTcar State and Nationals points' award for that night. Any driver refusing to sell his/her engine the first time is fined \$200.00 and is suspended for the next racing event at their home track and one (1) week from all DIRTcar sanctioned race tracks. The second infraction for a driver refusing to sell their engine is a \$600.00 fine and a suspension from all DIRTcar sanctioned tracks for 30-days.

H.) All claimed engines must be removed from the car at the track. The buyer must examine the engine before removal. Once removal has started, the sale is final. Any sabotage to claim an engine will result in the saboteur being suspended from all DIRTcar races for 30-days and until the fine of \$1,000.00 is paid to DIRTcar.

I.) To claim an engine, the claiming driver must have raced at least one-half of the sanctioned events at the sanctioned track where the claim is made or at a minimum the three (3) most recent consecutive feature events at that track. A driver can have his/her engine claimed at any time. No claim can be made against a driver on his/her first night at a sanctioned track.

## **15.2 Transmission & Driveline**

- A.) The drive shaft must be made from magnetic steel. The driveshaft must be painted white with the car number clearly labeled on the drive shaft.
- B.) Aluminum, fiberglass, or carbon fiber drive shafts will not be permitted.
- C.) A 1/2"-inche x 2"-inch 18-gauge steel drive shaft hoop is mandatory. The drive shaft hoop must be at least six (6") inches behind the universal-joint. Two hoops are strongly recommended.
- D.) All competitors are encouraged to perform systematic checks on their drive-train.
- E.) Direct drives and/or any type devices will not be permitted.
- F.) The transmission must be bolted to the engine. All cars must have forward and working reverse gears and be able to shift to forward or reverse with engine running. BERT-type transmissions will be permitted.
- G.) Clutch-type transmissions must be equipped with explosion-proof steel bell housing. In lieu of an explosion-proof bell housing or if one is not available for your engine, a shield of at least 1/2"-inch x 6"-inches covering the clutch area 360 degrees securely fastened in place and fabricated from magnetic steel will be permitted.
- H.) The steering box must be O.E.M. Any-type rack and pinion style steering will not be permitted. The original bolt pattern that matches frame type must be used. In the cockpit, steering may be modified to suit the driver but must remain on the left side of the vehicle. Moving the steering mechanisms to the center of the vehicle will not be permitted.

## **15.3 Chassis/Frame**

- A.) Only factory production full 1950 or newer parallel American passenger car frames will be permitted. The frame must be complete in front of firewall. Cutting of the frame in any way in front of firewall will not be permitted.
- B.) The frame must remain unaltered and must meet the requirements of the attached drawing.
- C.) The Right side frame rail may not be altered and/or raised and/or moved from the stock OEM location in any manner and must measure a maximum of six (6) inches from the ground to the bottom or lowest edge of the frame rail.
- D.) The front cross member may be notched to allow clearance for the radiator only. The cross members must be plated to retain complete box configuration.
- E.) Jeep, Bronco, 4-wheel drive, front wheel drive or sports car frames will not be permitted.
- F.) The minimum wheelbase permitted will be 108" inches. The maximum wheelbase permitted will be 112" inches.
- G.) The rear of the frame may be altered to accept leaf or coil springs. Any coil spring must be a minimum of 4-1/2" diameter.
- H.) Fiberglass lift bars and/or rear torsion bars will not be permitted.
- I.) Any frame may not be widened or narrowed and must be able to support the roll cage on both sides and must be full and complete on both sides.
- J.) The minimum frame and body height from ground is four (4) inches.
- K.) The front bumper must be mounted to the ends of the frame with the bottom loop parallel to the ground.
- L.) A minimum of 1" diameter tubing and/or pipe is required to for towing of the vehicle.
- M.) The rear bumpers must be constructed of tubing and/or flat stock. The rear bumpers must protect the fuel cell.

N.) The bumper(s) (front and rear) when measure from their center(s) must have a minimum of 25" inches of ground clearance. There will be a two (2) inch tolerance, plus or minus regarding this dimension. The rear bumper and/or the nerf bars must not extend beyond the width of rear tires. All bumpers must have round edges. Sharp edges on any bumper and/or bumper surface will not be permitted.

O.) The brace bars forward of the roll cage must not extend higher than stock hood height.

P.) The rear push bars must not extend beyond six (6") inches of the rear quarter panel(s).

Q.) All side bars and bumpers must be capped on ends.

R.) The maximum overall width of the car, front and/or rear, shall not exceed 78" inches when measured from the outside of the tire tread on both sides of the vehicle. A maximum one (1") inch spacer between the hub and wheel will be permitted. Steel and/or aluminum spacers will be permitted, provided the overall width of the vehicle does not exceed 78"-inches.

#### **15.4 Weight**

A.) All added weight(s) must be painted white with the car number clearly labeled on each weight.

B.) All added weight(s) must be securely mounted to car with minimum of two (2) 1/2"-inch bolts that pass completely through each weight and the car. Weights that are mounted on the rear bumper or outside the body of the car will not be permitted. All added weight must be mounted below all windows and the interior sheet metal.

C.) Any car that loses any weight(s) during any event may be fined up to \$500.00.

D.) The minimum weight of car with driver at all times including after the race is 2,400 lbs.

E.) The 602 GM Crate Motor will be permitted with a minimum weight with driver at all times will be 2250 lbs.

F.) The 604 GM Crate Motor will be permitted with a minimum weight with driver at all times will be 2300 lbs.

F.) All weight determinations will be measured on the scales selected by the local track officials and/or by DIRTcar Officials for each racing event. There will be no weight tolerance after the completion of any racing event.

#### **15.5 Fuel Cells and Fuel**

A.) All cars must have fuel cells. The maximum capacity for the fuel cell will be 32 gallons. The fuel cell must be completely enclosed in an 18-gauge magnetic steel container. Aluminum fuel cell containers will not be permitted. All fuel cells must be completely visible. All fuel cells must have a minimum of 2"x2" inch x 1/8"-inch steel straps surrounding them. The fuel cell must be protected in the rear of axle by securely-mounted (welded) roll cage tubing.

B.) Any driver competing with a fuel cell that has a capacity greater than 32-gallons will lose all winnings and points for that event and fined \$1,000.00.

C.) Any driver must be prepared to drain fuel upon request for measurement of the fuel cell.

D.) The fuel cell must not extend lower than protective tubing.

E.) Racing gasoline or alcohol will be permitted.

F.) Nitrous oxide, nitrous methane, propylene oxide or any type of additives will not be permitted.

G.) Fuel may be inspected at any time during any event.

H.) All fuel cells must have check valve in breather and filler check valve.

#### **15.6 – Body**

**(See drawing diagram for reference – There may be dimensions referenced in the drawing diagram that are not referenced in written rules and vice versa. All dimensions whether written and/or referenced in the drawing diagram dimensional are rule(s).)**

- A.) All bodies must follow dimension(s) and the appearance as shown in diagram. The body shall be the fabricated modified body from approved vendors.
- B.) The front windshield and rear window support must be stock appearing. The front window support(s) may have a clear Lexan support of no more than 16" inches including the roof post at the bottom and going straight to the roof. The support must be securely fastened in a positive manner.
- C.) The front roof post must be in a straight line from top to bottom.
- D.) The sides of the engine compartment will remain open. Any side panels in the engine compartment area will not be permitted. A five (5") inch drop on either side of the hood will be permitted and it must be enclosed at the rear of the hood. The firewall on driver's side must meet the front of the door.
- E.) The top of the doors must remain in line with the rear engine plate. The bottom of the doors may extend a maximum of eight (8") inches past the motor plate toward the front of the vehicle.
- F.) The side fins and/or flanges of any kind along the length of the entire car (hood, front – nose and/or roof) will not be permitted.
- G.) The bodies should extend no further forward than the back of the block.
- H.) A maximum of one (1) stone deflector, for rear mounted oil pumps, oil filters, and for the main oil tank will be permitted. The deflector may be made of steel, aluminum, or heavy gauge wire. The cover may only be mounted near the unit it is designed to protect with a maximum size of eighteen (18"x18") inches square and mounted only from the upper right frame rail to the lower right frame rail.
- I.) The minimum roof height is 42" inches with a maximum height of 52" inches.
- J.) The minimum deck height is 28" inches with a maximum height of 38" inches.
- K.) All cars must have a car number on both sides and the roof that are at least 18" inches in height and 14" inches in width.
- L.) The driver's last name must be displayed under the car number in a legible font that is a minimum of eight (8") inch high letters.
- M.) There must be a minimum of two (2") inches of tire clearance from the body.
- N.) The minimum ground clearance will be four (4") inches.
- O.) The measurement from center of the hub to the rear top of deck will be a minimum of 34" inches and a maximum of 48" inches.
- P.) The maximum body width at the body's widest part will be 68" inches. The minimum of width at the body's narrowest part will be 53" inches. The bottom of the doors may have a maximum width of 68" inches.
- Q.) On the left side the rear of the door may flare out six (6") inches for tire clearance.
- R.) The bottom of the flare must be curved and rounded not pointed in any fashion.
- S.) The maximum rear width of car must be 67" inches at the widest point.
- T.) The maximum roof width will be 50" inches with a minimum of 44" inches.
- U.) The maximum roof length will be 56" inches with a minimum roof length of 41" inches.
- V.) The maximum height on rear roof post vertical is **5" inches**.

W.) The nose piece shall not be longer or wider than frame horns and shall not be attached any further back than the radiator. The nose piece must not extend past the leading edge of the front bumper. The nose piece must have a minimum of six (6") inches from the ground to the bottom edge of the nose piece.

X.) The spoiler shall be a maximum of 5" inches tall. Any spoiler angle will be permitted. Three (3) spoiler supports may be used; this includes side spoilers. The spoiler supports and side spoilers shall be 5" inches tall in the back and 2" inches tall in the front with a maximum total length of 12" inches at the bottom.

Y.) The spoiler may be fabricated from lexan or aluminum. You may use the roof post/spoiler kit. The kit has the roof post and spoiler fabricated in one piece. If the kit is utilized the spoiler height must remain 5" inches.

### **15.6.1 – Interior and Driver Compartment**

A.) All windows must have a minimum 11"-inch vertical opening. The entire interior must have 11"-inches of clearance from the interior deck to the roof and all sections of the roll cage. \*\*\* - For 2009 it is highly recommended and mandatory in 2010; The minimum window opening will be 12" inches. The interior deck sheet metal to the right side of the driver must be fabricated on an angle from the driveshaft tunnel to the right side window to promote ease of exit for the driver through the right side and or front window opening.

B.) A master ignition switch within easy reach of the driver is mandatory. The switch must be clearly labeled "ON" and "OFF".

C.) Hydraulic and/or pneumatic weight jacks, trackers, or similar adjustable components of any type will not be permitted.

D.) Mirrors of any type will not be permitted.

E.) The rock guard should end at a point perpendicular to the steering wheel.

F.) The driver's compartment must be sealed from the engine and the race track. The rear bubble of the hood should be closed and sealed from the driver.

G.) The maximum slope/rake of the interior sheet metal "shelf" front-to-rear is 4"-inches. The interior sheet metal must remain flat and level from side-to-side.

H.) The top of the interior must be flush with the top of door and quarter panels.

### **15.6.2 – Roof & Roof Supports** (see drawing diagram for reference)

A.) All roofs must be full size. Half-moon roofs will not be permitted. The roof may not be mounted more than 12" (twelve inches) past the rear axle.

B.) Wings, roof spoilers or ground effects of any kind will not be permitted.

C.) All flat type roofs will be allowed a maximum 1"-inch difference in height between the front of the roof and the rear of the roof.

D.) All curved type roofs will be allowed a maximum of 5"-inches in the front and 2"-inches in the rear. The break in the roof must be within 6"-inches from the center of the roof.

E.) Wedge roofs will not be permitted.

F.) Dished roofs will not be permitted. Roofs must be rounded side-to-side. Bead rolls will be permitted.

G.) The rear roof supports may not extend past the front side of rear upright of the roll cage.

H.) The side vents on the front roof posts may extend rearward from the lowest point, a maximum of 16"-inches, then at a 90 degree angle to roof for one (1) configuration, side vents must meet the outside of the car.

- I.) The roof side panel window size must be a minimum of 10"-inches x 15"-inches and must match drawing number -2- side view. A maximum crown of two (2) inches will be permitted, measured from the center of a common tangent point on either side of the crown.
- J.) Any sun shield must be on hinge for easy exiting, taping will not be permitted. The window opening must remain at a minimum of 12"-inches.
- K.) All race cars must meet the measurements illustrated in the DIRTcar drawing
- L.) There are only 5 (five) approved roof supports to choose from.
- M.) The roof should be single thickness of material. The roll bar hoops must be exposed for inspection.
- N.) Flat type roofs will be measured from the front edge of the roof down to the interior and measured from the rear edge down to the interior, assuming a flat interior. A 1"-inch difference between the two measurements will be permitted. If the interior has been changed, the measurement will be from the front edge of the roof to the ground, and the rear edge of the roof to the ground. A one inch difference between the two measurements will be permitted.
- O.) If the roof is curved then a level will be placed on the top of the car and if the roof is 5"-inches or less in the front and 2"-inches or less in the rear and the break is in the middle then the roof will be permitted.
- P.) The roofs on these cars will be stock appearing. If a DIRTcar and/or local track official determines the roof does not meet the requirements as stated above then a penalty as determined by the official may be determined prior to competition, additional weight and/or other penalties, unless the roof can be returned to within the parameter as stated above prior to competition in the event that the roof was inspected for.

## **15.7 – Suspension**

- A.) Any "live axle"-type rear ends will not be permitted.
- B.) Quick change rear ends will be permitted. Only magnetic steel tubes will be permitted.
- C.) Aluminum birdcages will not be permitted.
- D.) Independent rear suspensions will not be permitted.
- E.) Only floater hub assemblies will be permitted.
- F.) The front suspension must be O.E.M. and be in stock location. The front suspension must have replaceable stock part(s) from the same type of suspension.
- G.) Aluminum spools will be permitted.
- H.) Steel coil-over eliminators and/or steel/aluminum coil-over kits will be permitted. The coil-over eliminators and/or coil-over kits must conform to the shock and spring rules. In the rear of the car a minimum 5"-inch spring is required.
- I.) All springs must have a tethered and/or cable system in place to securely fasten them in position in the car.
- J.) Aluminum shocks, shells, aluminum hubs, aluminum A-frames, aluminum rear-end, aluminum tubes and/or other aluminum suspension parts will not be permitted.
- K.) Only steel body, one piece non-adjustable shocks will be permitted. Adjustable shocks will not be permitted.
- L.) Coils over shocks of any type on the front of the car will not be permitted.
- M.) Only one shock per wheel will be permitted. Lay down shocks less than 12" (twelve inches) away from brake rotor will not be permitted. Additional shocks in other locations will be permitted.

- N.) The shock absorber claim will be \$120.00 per shock absorber.
- O.) Only stock passenger car spindles will be permitted. Fabricated spindles will be permitted.
- P.) Alterations and/or relocation of the lower A-frames will not be permitted. DIRTcar approved after-market lower control arms, which are mounted in the OEM location will be permitted. All after-market lower control arms must have an official DIRTcar-approved and numbered decal displayed for ease of inspection at all times.
- Q.) Tubular-type upper A-frames will be permitted. The upper A-frame mounting locations may be altered. Aluminum cross shafts will be permitted.
- R.) Composite leaf springs will be permitted.
- S.) Aluminum shackles will be permitted.

#### **15.7.1 - Brakes**

- A.) All cars must be equipped with a working braking system on all four wheels and all four wheels must be able to stop/brake at all times.
- B.) Only magnetic steel rotors will be permitted. Carbon fiber and/or aluminum rotors will not be permitted. Drilling, lightening and/or any alteration to the brake rotors or calipers will not be permitted.
- C.) Only stock O.E.M. calipers will be permitted.
- D.) Only stock O.E.M. rotors will be permitted. Single disc brake rotors or scalloped rotors will not be permitted.

#### **15.8 – Wheels and Tires**

- A.) The tire rule may be amended by bulletin.
- B.) The DIRTcar approved tire is the Hoosier A-40, D-40 or H-40 compounds in the DIRTcar plated tire 26.5/8.0/15 or 27.5/8.0/15. The maximum width of the tire will be 9" inches.
- C.) Grooving of any tire will not be permitted. Siping will be permitted on the A-40 and H-40. Recapping of an approved tire is not permitted.
- D.) Any local track and/or DIRTcar official can confiscate any tire at any time and during any DIRTcar event to be evaluated and analyzed including verification using a tire durometer. Tires may also be submitted for further chemical analysis.
- E.) Defacing or altering any of the manufacturer's identification markings, letters, words, numbers, on any tire will not be permitted. The tire compounds may be covered by duct tape as long as the local track and/or DIRTcar officials are able to remove the covering at any time for inspection purposes. Any alteration of tires may result in immediate suspension from all DIRTcar racetracks and/or events and/or penalties deemed appropriate by local track and/or DIRTcar and/or World Racing Group Supervisory Officials.
- F.) Tire softeners and/or chemicals designed to alter the chemical characteristics of the tire and/or the tire surface will not be permitted.
- G.) Mud plugs are will be permitted on all four wheels. Bead locks will be permitted on the right side only. The mud plug must have the car number on it.
- H.) Only 8-inch DIRTcar approved and labeled racing wheels will be permitted.
- I.) All wheels must be conventional one-piece magnetic steel and must be mounted with lug nuts. Aluminum, plastic and/or carbon fiber wheels will not be permitted.
- J.) All wheels must be fastened to the hub with five lug nuts.

#### **15.9 – Personal Protection Equipment**

### **15.9.1. General**

A.) It is the sole responsibility of each competitor for the effectiveness and proper installation, per the manufacturer's specifications to be adequate for competition at every event. Each competitor is expected to investigate and educate themselves for continuing improvement regarding their own personal safety equipment.

### **15.9.2 Seat Belt/Restraint System**

A.) Each car should be equipped with an SFI 16.5 or SFI 16.1 approved seat belt restraint system until the date of the belt expiration (usually two years). Seat belts restraint systems shall be installed in accordance with the directions and application of the system supplier or manufacturer.

B.) Seat belt webbing that comes into contact with any sharp or unradiused metal edge should be protected from that edge by means of push on grip vinyl trim.. Seat manufacturers supply the seat with trim protecting the webbing from abrasion or cutting under impact conditions and should be used to their specifications.

C.) It is the responsibility of the driver, not the Officials or the Promoter to ensure that his/her seat belt restraint system and all components are SFI approved, correctly installed, maintained and properly used.

### **15.9.3 Protective Clothing**

A.) Each driver should wear a fire resistant uniform meeting the SFI 3.2A/5 specification and display a valid SFI 3.2A/5 label.

B.) Each driver should also wear fire resistant accessories that effectively cover the remaining parts of the body. Shoes and gloves should meet the SFI 3.3 specification and display a valid SFI.3label.

### **15.9.4 Seats**

A.) An aluminum seat built specifically for the purpose of competition in auto-racing events will be required

B.) High-back Aluminum (stockcar style) seats should be securely mounted to the frame as recommended/required by seat manufacturer and chassis manufacturer.

C.) Head rest (behind the head) should include padding. All areas surrounding the head should have padding

D.) A right head net or support is required. Head nets must be equipped with quick release mechanisms

E.) The seat must be mounted a minimum of 30" (inches) from the center of the rear end, measured at the bottom of the seat

### **15.9.5 Helmets**

A.) Driver should wear a full face helmet, with at least a valid SA 2000 or SA 2005 Standard Snell and/or a valid SFI 31.1, SFI 31.2 or SFI 31.1 2000 label.

B.) The driver should wear the helmet in accordance with the directions provided by the helmet manufacturer and/or supplier.

C.) If a head and neck restraint system is connected it should conform to the manufactures mounting instructions.

D.) Head and Neck restraints are strongly recommended.

### **15.9.6 Other**

A.) No sharp or protruding edges in or around the cockpit, which would impede the driver's rapid exit from the car.

B.) Windshield screens with a minimum of .090 inch screens must be securely fastened

C.) An electrical engine shut off switch is required. The switch must be clearly labeled and within the reach of the driver.

D.) A fuel shut off valve is required. The valve must clearly labeled and within reach of the driver.

E.) Flame retardant seat, roll bar, knee and steering pads or padding are recommended

### **15.10 – Roll Cage**

A.) All cars must have a roll cage. The roll cage must be approved prior to competition and it must be welded to the frame. The driver's head must not protrude above the top of the roll cage with the driver's helmet on. The top of the roll cage must extend above the top of the driver's helmet by a minimum of one (1) inch. The entire roll cage and all roll bar pieces must be fabricated from magnetic steel a minimum of .095" in thickness.

B.) The driver side door bars must be parallel to the ground and located perpendicular to the driver. The side bars must be welded to the front and rear of the roll cage. No brazing or soldering is permitted. The door bars must have a minimum thickness of .095" and must have a minimum of 1-1/2" diameter. On the driver's side there will be a minimum of three (3) door bars.

C.) Foot protection is mandatory. One piece of magnetic steel tubing, a minimum .095" in thickness, must be fastened and/or welded across the back of the engine with vertical tubing a minimum of .095" thick.

D.) The door side roll bars are mandatory and must extend into the door panels.

E.) The roll cage must consist of continuous hoops that are no less than 1-1/2" in diameter and must a minimum thickness of .095".

F.) The roll cage must be mounted securely (welded) to the frame in a minimum of 6 (six) places.

G.) The roll cage must consist of a configuration of front and rear hoops connected by tubing on the sides and/or side hoops. Roll cage must be securely supported and braced. Gussets to brace any portion of the roll cage will be permitted.

### **15.11 – Other**

#### **Section 15.11.1 – Electronic Devices & Traction Control**

A.) All electronic and/or computerized wheel spin and/or acceleration retardation traction control devices will not be permitted. Controlled timing devices attached to or controlling accelerator or rotation of wheel will not be permitted.

B.) All traction control devices utilizing wheel sensors and/or any means of measuring ground speed to control wheel spin will not be permitted.

C.) Adjustable ping control devices, dial a chip controls, timing controls or automated throttle controls will not be permitted in cockpit or driver accessible areas.

D.) Adjustable restrictor plates will not be permitted.

E.) Any remotely controlled components inside or outside the cockpit of any competitor's racecar will not be permitted.

F.) Radios or devices for transmitting voice or data will not be permitted, either in the racecar or on anyone connected with the car.

G.) The uses of pit boards or colored flashlights are prohibited

### **15.14 SERIES DECALS AND PATCHES**

A.) All participants shall display required decals as provided on decal verification sheet to be allowed to compete.

B.). Series Decal on both side of the car is mandatory, Drivers series patch mandatory to receive point fund distribution.

C.). To receive any contingency sponsorship awards, team must meet the requirements of the award such as; decals, patches, product use, product verification

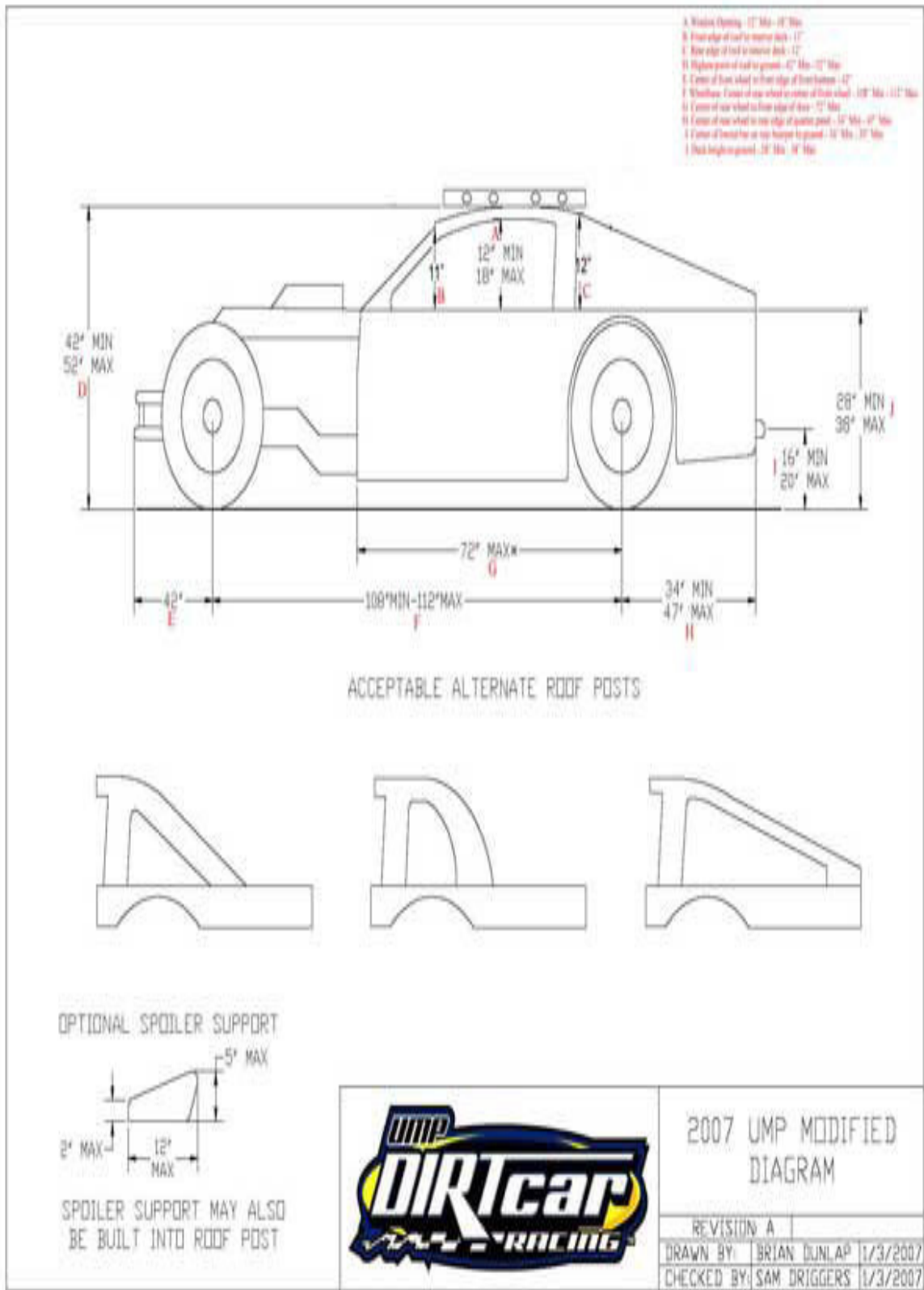

- Dimensions are to either the top or bottom surface of the frame rail as indicated.

- Some dimensions may not apply as frame can be trimmed for front bumper.

- All dimensions must be within 0.250-inch tolerance. Exception is variances officials verify as crash damage.

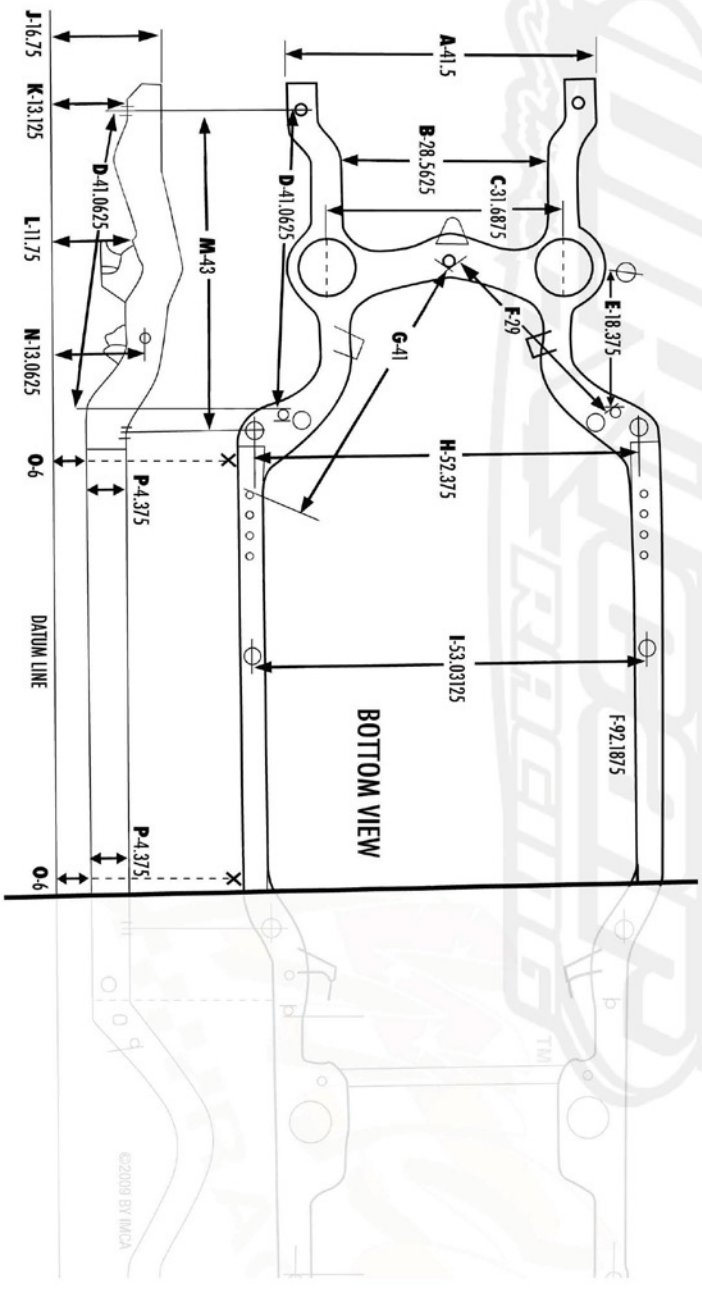

- A.** 41.5 - inches to outside of frame rail
- B.** 28.5625 - inches between side rails at lower steering gear bolt and idler arm mounting surface.
- C.** 31.6875 - inches TRAM top side between upper control arm inner shaft seats (at shim contact area).
- D.** 41.0625 - inches from center of hole (frame horn bottom), to front edge of hole.
- E.** 18.375 - inches from center of lower ball joint grease fitting, to front edge of hole. Maximum difference of 0.5 inches from side to side of frame.
- F.** 29 - inches from rear edge of hole, to front edge of hole.
- G.** 41 - inches from rear edge of hole, to front edge of hole.
- H.** 52.375 - inches from center of hole to center of hole.
- I.** 53.03125 - inches from center of hole to center of hole.
- J.** 16.75 - inches to top surface of side rail.
- K.** 13.125 - inches to bottom surface of side rail.
- L.** 11.75 - inches from bottom surface of side rail (just forward of coil spring opening) to datum line.
- M.** 43 - inches measured from center of hole to center of hole.
- N.** 13.0625 - inches center of hole to datum line.
- O.** Locations for measuring ride height. Dimensions J, K, L and N should be measured at 6 inch ride height.
- P.** 4.375 - inches from top to bottom of side rail surface.